

NV SERIES

SUBWOOFER MODELS

NV-SW12, NV-SW15

FUSION[®]

FUSION CULTURE

There's no point doing something if no one notices. We've always believed the way to make things happen is by getting noticed. From our product, to our demo cars, to our events, FUSION is about making some noise.

Now you are ready. Step out of the shadows and announce you've arrived in a world where the old limits are left behind. Where technology is creatively combined with the latest in product innovation. Where new levels of entertainment are delivered with outstanding performance and quality. Our development team create distinctively different products; subwoofers, amplifiers, speakers and peripherals that redefine what can be done in car audio.

Leave the old behind and push the limits of what can be achieved in car audio. Make some noise.

For more information about FUSION Car Audio visit our website at www.fusionelectronics.com or email technical@fusionelectronics.co.nz

NV SERIES

Embrace the ultimate in power. The NV Series is the pinnacle of modern car audio. State of the art engineering ensures the most refined sound available is delivered at unparalleled levels. The NV Series represents the finest work FUSION has achieved; designed and manufactured to the highest level with no compromises.

To optimise your FUSION experience, we recommend you have your FUSION product installed by an Authorised FUSION Dealer. Please read the warranty policy, keep your purchase receipt and original packaging.

If after reading this manual you still have questions regarding this product, please contact Technical Customer Services via email technical@fusionelectronics.co.nz

TABLE OF CONTENTS

- SUBWOOFER FEATURESpg 4
- SUBWOOFER THEILE/SMALL PARAMETERSpg 5
- SUBWOOFER DIMENSIONS NV-SW12pg 6
- SUBWOOFER DIMENSIONS NV-SW15pg 7
- ENCLOSURESpg 8
- ENCLOSURE TEST CURVESpg 10
- TECH TIPSpg 12
- TROUBLE SHOOTINGpg 17

RECORD YOUR PRODUCT DETAILS HERE:

MODEL NUMBER _____ DATE OF PURCHASE _____

AFFIX RECEIPT HERE

WARNING! Audio Systems can produce sound levels over 135dB. Continuous exposure to sound pressure levels over 100dB may cause permanent hearing loss!
Please watch for emergency vehicles as warning signals may not be heard. USE COMMON SENSE!

SUBWOOFER FEATURES

FUSION subwoofers are low frequency drivers capable of delivering extremely high bass levels from small enclosures. In order to achieve the maximum performance from your new FUSION Subwoofer, please use one of the recommended size enclosures that best suits your application. Sealed and vented enclosure sizes can be found in this manual.

BASKET

NV Series Subwoofers feature a uniquely high pressure cast aluminium basket. Development of the NV Series basket allows rigidity and style for any custom install. Finished in a protective metal silver paint and detailed with FUSION green enhancements, the basket displays impressive strength and style.

CONE ASSEMBLY

Development of the high performance pressed paper cone, creates a dynamic low bass response and high power performance. The cone is finished in a dynamic silver with NV Series super graphic, catering for style, strength and sound performance.

SPIDER

In order to keep the cone assembly balanced and linear, FUSION has used green poly cotton flat spiders to reduce the mechanical distortion for better sound quality.

VOICE COIL

NV Series Subwoofers use dual 2 ohm configuration. This allows a multitude of wiring combinations for your amplifier system (please see wiring configurations in this manual). NV Series Subwoofers utilise high temperature, multi wound black aluminium voice coils.

EXTENDED POLE PIECE

Recognising that an increased linear magnetic field for the subwoofer encourages a better low frequency response, FUSION has extended the internal pole piece to achieve this. The extended pole piece also decreases distortion.

MOTOR STRUCTURE

The motor structure is constructed from the highest strontium magnetic material triple stacked and capped with a diamond cut FUSION back plate, has enabled increased power handling and larger excursion. With the additional venting holes we assure consistent booming.

SUBWOOFER THEILE/SMALL PARAMETERS

Subwoofer Parameters	NV-SW12	NV-SW15
MAX Power Rating (Watts)	2000	2500
RMS Power Rating (Watts)	1000	1100
Coil Height (Hvc) (mm)	40	40
Compliance (Cms) (uM/N)	180.8	146.18
Cone Area (Sd)	47.92	77.93
D.C.Coil Resistance (Re)	0.94	0.88
Electrical Q (Qes)	0.47	0.552
Force Factor (BL)	8.53	8.4
Free Air Resonance (Fs)	26.38	23.62
Frequency Response (Hz)	21Hz – 500Hz	19Hz – 500Hz
Gap Height (Hag) (mm)	10	10
Impedance (Nominal)	1	1
Inductance (Le) (mH)	0.5	0.51
Linear Excursion (X-Max Total)	40	40
Mechanical Excursion	15	15
Mechanical Q (Qms)	6.42	6.17
Moving Mass (Mms)	219.88	285.85
Sensitivity (dB)	85	87
Total Loudspeaker Q (Qts)	0.44	0.506
VAS (Litres)	52.21	126.07
VAS (CuFt)	1.845	4.45
Magnet Structure (Oz)	308	308
Total Loudspeaker Displacement (Litres)	8	12

DIMENSIONS

SUBWOOFER

NV-SW12

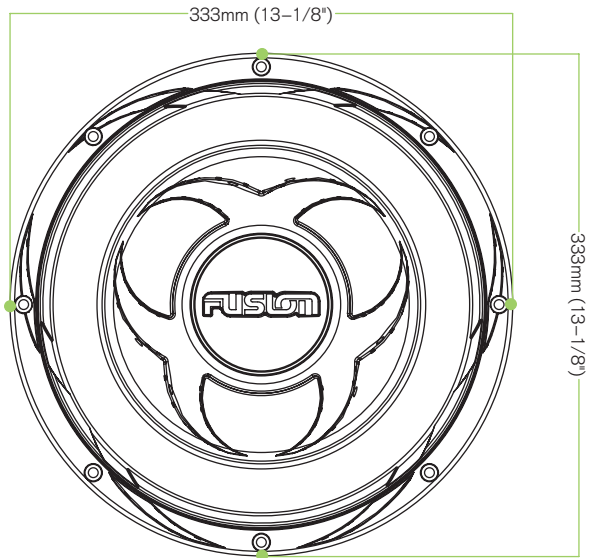
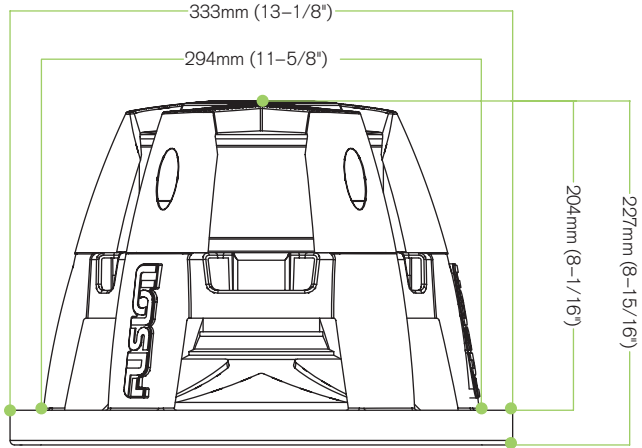

DIMENSIONS

SUBWOOFER

NV-SW15

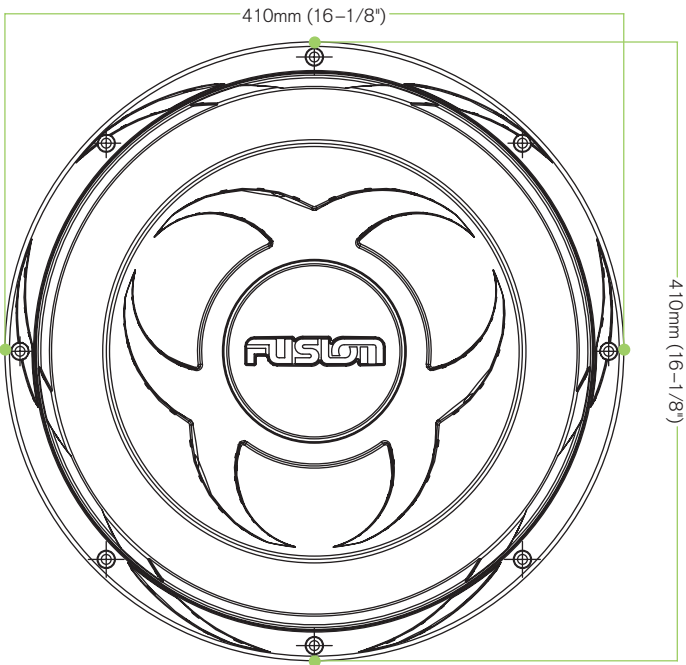
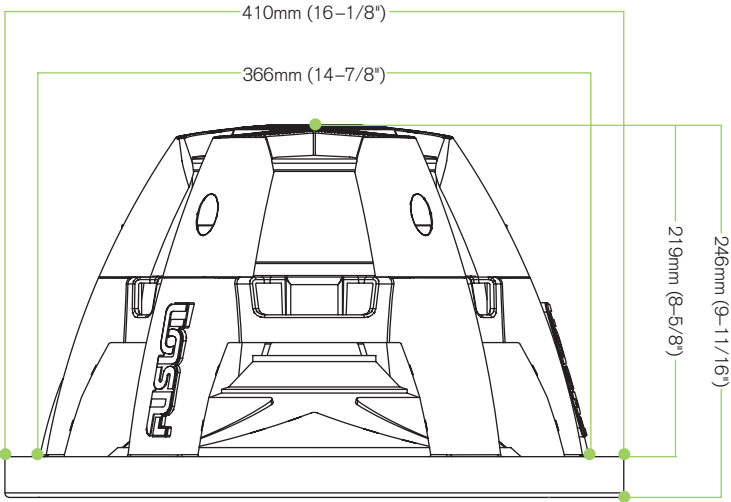

ENCLOSURES

All enclosures include port and subwoofer displacement. All ports are circle aero ports unless otherwise stated.

Ported Enclosures: A ported enclosure is generally larger than a sealed enclosure

Sealed Enclosures: A sealed enclosure will be the smallest enclosure you can build. It will have a tight low frequency response, but not as low as a ported enclosure.

OPTIMUM ENCLOSURES

PORTED	NV-SW12	NV-SW15
Volume (litres)	87.38	106.4
Volume (cu.ft)	3.086	3.759
Port diameter (mm / in)	101mm / 4"	101mm / 4"
Port length (mm / in)	304mm / 11-15/16"	289mm / 11-3/8"
Tuned frequency (Hz)	28	26.2

SEALED		
Volume (litres)	55.62	75.7
Volume (cu.ft)	2.043	2.68
Tuned frequency (Hz)	45	37

ENCLOSURE CONSTRUCTION

All enclosures should be constructed from 18mm (3/4") Medium Density Fibre board. Enclosures should be glued and screwed, because MDF is porous. FUSION recommends sealing the internal sides with a polyurethane sealer prior to installation. To accurately cut the subwoofer hole use the unique FUSION ruler guide included inside the FUSION Subwoofer packaging.

ENCLOSURE PLACEMENT

An important factor is to place the subwoofer enclosure as far back in the vehicle as possible, so that the natural bass gain of the vehicle is utilised. If your vehicle is a hatch back, always experiment with which direction the subwoofer is facing. Facing the subwoofer towards the rear of the car, should enhance the low down bass that NV Series Subwoofers are designed to produce.

ENCLOSURE TUNING

When tuning the system it is always a good idea to try running the subwoofer out of phase (which means switching the speaker wires around) with your other speakers. Do this and listen to the system to see if the perception of bass is more from the subwoofer location or the front speaker location. Which ever way gives the better perception that the bass is coming from the front speakers, would quite safely guarantee the subwoofer is wired correctly.

CALCULATING ENCLOSURE 'BOX' VOLUME

Cuft:

To calculate Cuft multiply the height (A), width (B), depth (C) in inches, then divide that number by 1728.

Example: 10" high x 18" wide x 12" deep = 2160 inches³
Divide 2160/1728 = 1.25 ft³

Litres:

To calculate Litres, multiply the height (A), width (B), depth (C) in centimetres, then divide that number by 1000.

Example: 25.4cm high x 45.72cm wide x 30.48cm deep = 3539cm³
Divide 35396/1000 = 35.39 litres

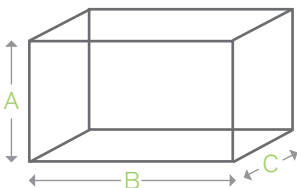

ENCLOSURE TEST CURVES

SUBWOOFER

NV-SW12

SEALED

Amplitude Response (dB-SPL/Hz at 1 m) with 1200 watts

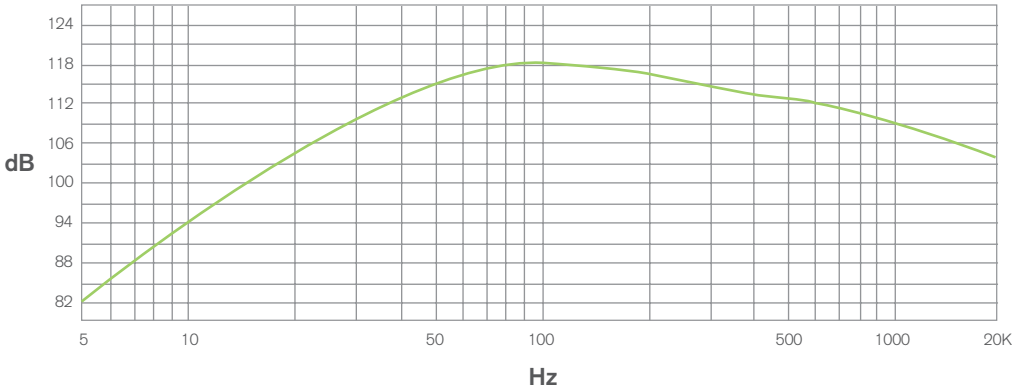

PORTED

Amplitude Response (dB-SPL/Hz at 1 m) with 1200 watts

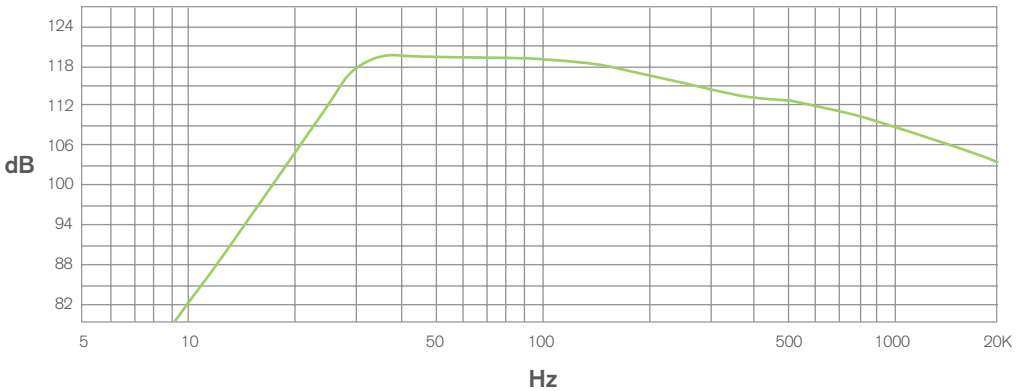

SUBWOOFER

NV-SW15

SEALED

Amplitude Response (dB-SPL/Hz at 1 m) with 1500 watts

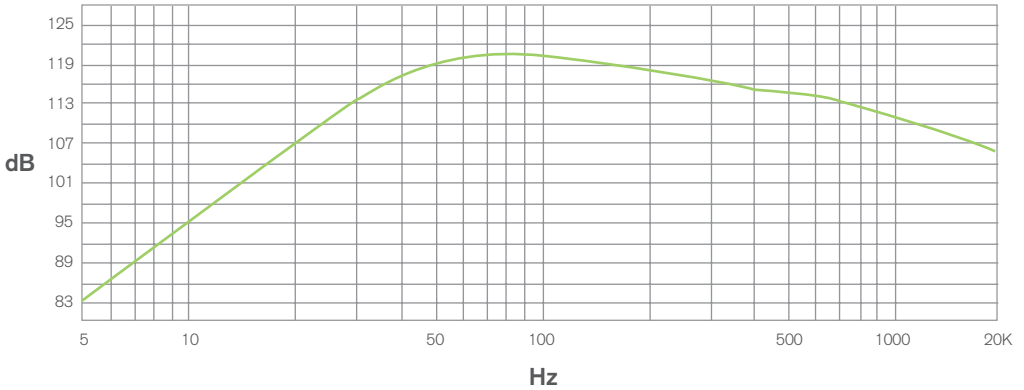

PORTED

Amplitude Response (dB-SPL/Hz at 1 m) with 1500 watts

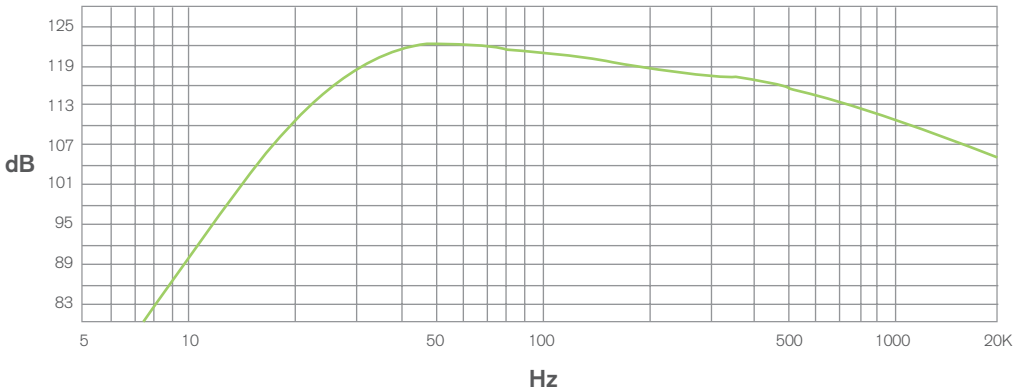

TECH TIPS

POWER CABLE CALCULATOR

TOTAL AMPERAGE	0-4 FT	4-7 FT	7-10 FT	10-13 FT	13-16 FT	16-19 FT	19-22 FT	22-28 FT
0 – 20	14	12	12	10	10	8	8	8
20 – 35	12	10	8	8	6	6	6	4
35 – 50	10	8	8	6	4	4	4	4
50 – 65	8	8	6	4	4	4	4	2
65 – 85	6	6	4	4	2	2	2	0
85 – 105	6	6	4	2	2	2	2	0
105 – 125	4	4	4	2	0	0	0	0
125 – 150	2	2	2	0	0	0	0	0

The above chart shows cable gauges to be used, if no less than a 0.5 volt drop is acceptable. If aluminium wire or tinned wired is used, the gauges should be of an even larger size to compensate. Cable gauge size calculation takes into account terminal connection resistance.

OHMS LAW SIMPLIFIED

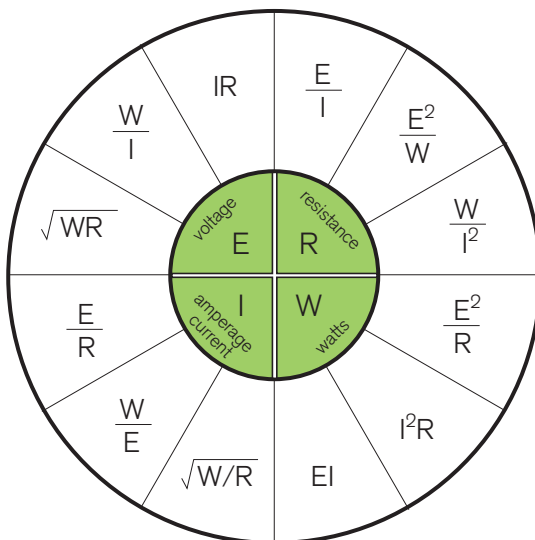

SUBWOOFER RULER GUIDE

Use the FUSION ruler guide to create a perfect subwoofer mounting surface.

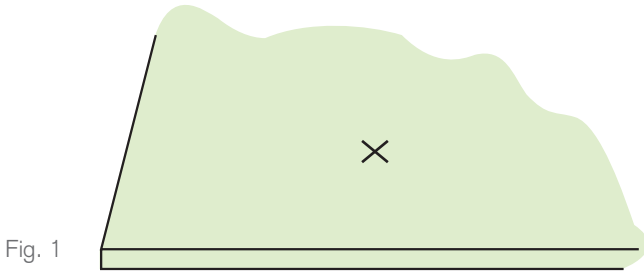

- 1: Mark the centre position on the MDF (Medium Density Fibre) board where the subwoofer is to be mounted.

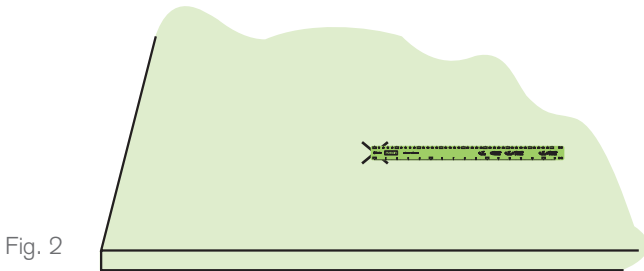

- 2: Fix the first hole (centre) to the marked out position on the MDF.

Fig. 3

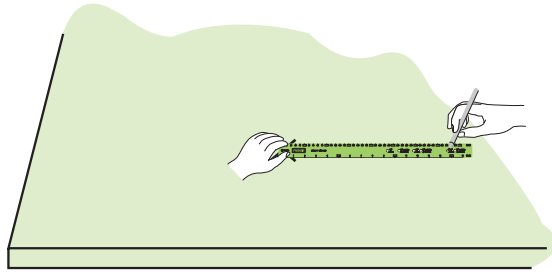

3: Insert a pencil into the correct subwoofer cut out measurement. 10", 12", or 15".

Fig. 4

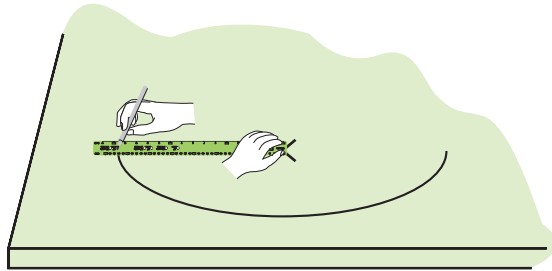

4: Scribe a perfect cut out diameter onto the MDF board.

Fig. 5

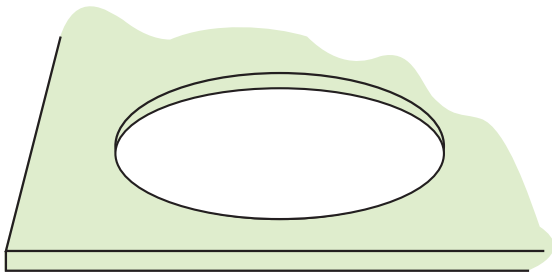

5: Using a jigsaw or router, cut out this measurement.

SERIES AND PARALLEL SUBWOOFER WIRING FOR DUAL VOICE COIL SUBS

Parallel Voice Coil Wiring (1 Ohm operation)

To wire a DVC subwoofer in parallel (to get 1 Ohm), use two short pieces of speaker wire and link the positive from one coil to the positive of the second coil, and do the same for the negative as shown in fig 1. Then wire the amplifier to opposite sides of the subwoofer in order to equalise any connection resistance.

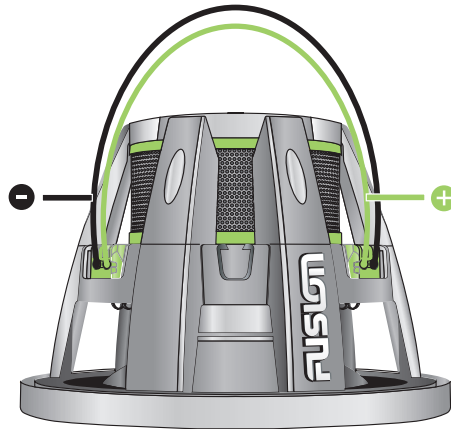

Fig.1

1 Ohm operation

Series Voice Coil Wiring (4 Ohm operation)

To wire a DVC subwoofer in series (to get 4 Ohms), use one short piece of speaker wire and link the positive from one voice coil to the negative of the second coil as shown in fig 2. Then wire the amplifier to opposite sides of the subwoofer.

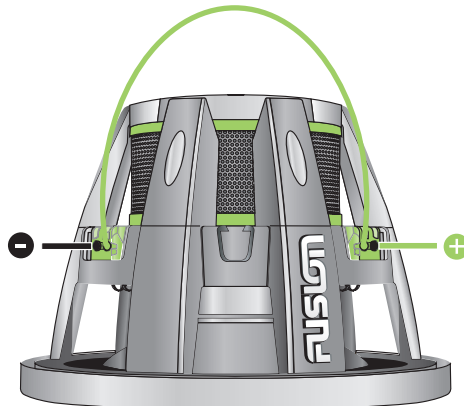
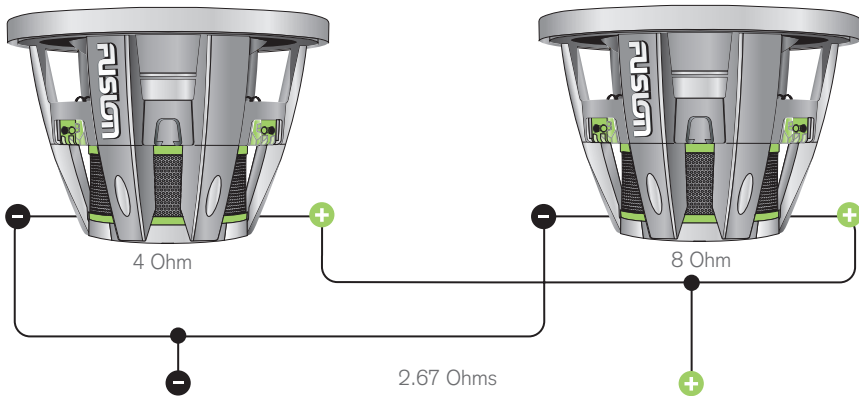

Fig. 2

4 Ohm operation

PARALLEL WIRING FORMULA FOR 2 SPEAKERS



$$\frac{R1 \times R2}{R1 + R2} = \text{LOAD IMPEDANCE}$$

$$\frac{4 \text{ Ohms} \times 8 \text{ Ohms}}{4 \text{ Ohms} + 8 \text{ Ohms}} = \frac{32}{12} = 2.67 \text{ Ohms}$$

SERIES WIRING FORMULA FOR 2 SPEAKERS

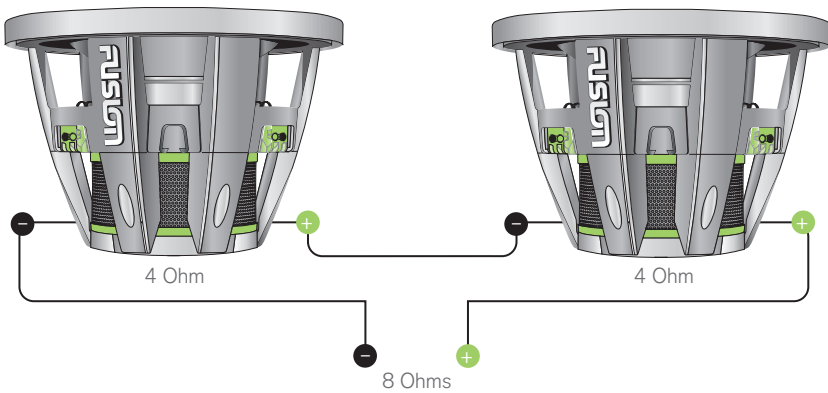

$$R1 + R2 = \text{LOAD IMPEDANCE}$$

TROUBLE SHOOTING

No sound from your subwoofer: Check amplifier and wiring connections.

Distorted sound: Check the connections from amplifier, processor or head unit.

Subwoofer makes unusual noise in sealed enclosure: The enclosure may have leaks causing a lack of back pressure. Remove the subwoofer and ensure the enclosure is completely sealed, use sealer and polyurethane to do this.

Ported enclosure makes an unusual noise: Possibly due to incorrect port used. The correct term is chuffing, and to rectify this you will need to increase the port area. The diameter will need to increase and the port length will need recalculating.

Bad smell: If you smell a burning smell, then chances are the subwoofer has been damaged. This can be due to the enclosure parameters being incorrect, too small an amplifier used and the subwoofer is receiving unwanted clipped signals or the music choice has enhanced bass notes played for long periods of time. Check the enclosure volume used and ensure the subwoofer is receiving clean audio signals from the amplifier.

Vehicle rattles: The best way to solve this problem is to add sound deadening material to the steel panels of your vehicle. Ensure all screws and plastic panels are affixed firmly.

INSTALLATION WARNING

- 1: Ensure the vehicle 12 volt lead is removed before any equipment is connected.
- 2: Investigate the vehicle's gas tanks, brake lines and electrical wiring locations before you begin installation.
- 3: Attach the product securely to the vehicle to prevent damage in the event of an accident.
- 4: Ensure all wiring is protected to avoid damage or pinching of the cables.



Specifications and design are subject to change without notice.